

The BMW D 190 W Marine Engine with reversing-type gearbox: 121 kW (165 bhp). Particularly suitable for displacement boats and fast planing cruisers through its compact dimensions and extremely low weight: 60 kg/132 lb less than most of its competitors.

This turbocharged diesel with charge air cooling also excels with its exceptional combination of technical features: 6 cylinders inline for particular smooth running free of vibrations. Turbocharging to provide powerful torque and flexibility at all engine speeds. Twin-circuit cooling fitted as standard for better corrosion-proofing and freedom of maintenance. Weight including gearbox 422 kg (928 lb).

Special features:

- One piece crankcase of cast iron built to the "tunnel" design, with transverse sections. Giving maximum stability and low weight
- 6 individual lightweight aluminium cylinder heads: better sealing properties with easy inexpensive maintenance
- Very quiet exhaust gas turbo-charger providing a smooth power curve throughout a wide engine speed range
- Aftercooler provides optimum efficiency
- Extra-large air filter for fresh air and a low noise level
- Water jacketed exhaust manifold made of V4A stainless steel
- Bosch distributor-type fuel injection pump with fuel supply geared to turbocharger pressure, maximum efficiency, improved fuel economy and considerably reduced exhaust emissions. Efficient combustion to provide optimum running smoothness free of vibrations
- All fuel pipes made of steel for maximum safety

- Compact twin-circuit cooling system with integrated header tank, heat exchanger and thermostat, oil cooler and thermostat
- Maintenance-free direct drive salt water pump by the camshaft and single-belt drive of the circulation pump and alternator by the crankshaft
- Extra pulley for driving additional components
- Complete corrosion-proofing by the application of a special two-component paintwork in the advance and main painting process

Conclusion:

The D 190 W has a wide range of exceptional advantages. This applies not only to the D 190 W but to all marine engines that bear the symbol of progressive engineering. BMW's complete range of marine engines for motor yachts and sailing boats offers all kinds of options and a wide choice of diesel and petrol units. You can choose from a wide range of optional extras and accessories to meet your personal requirements. And to make sure that you enjoy sheer boating pleasure for a long time to come, BMW Marine's international dealer organization has trained marine technicians at your service as well as a reliable and quick supply of parts.

V12 Engineering

Box 50, Ontario, Canada POX 1C0

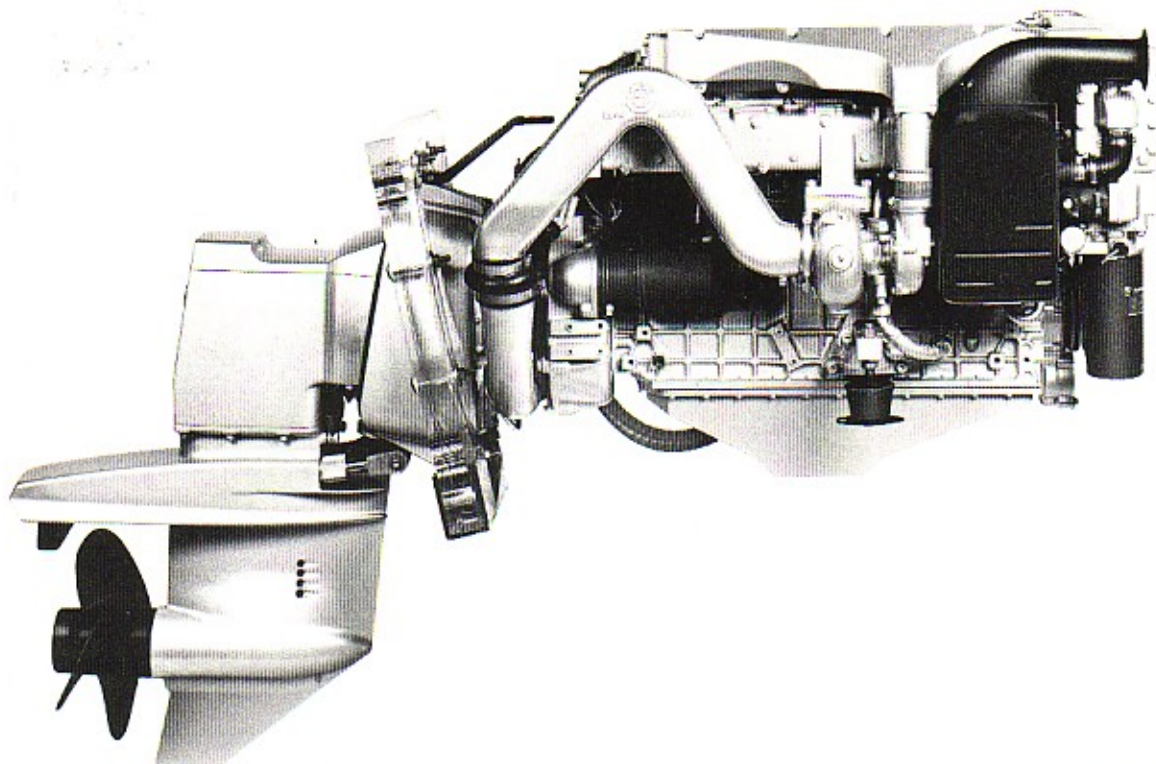

The BMW D190Z Marine Engine with stern drive: 121 kW (165 bhp). Particularly suitable for medium-size fast planing cruisers with twin-engine installation up to approx 10 metres (33') length.

This turbocharged diesel is ideally suited for the motor boat enthusiast who wishes to combine the rugged dependability of a diesel engine with the low weight and smoothness of a petrol unit.

The stern drive provides a unique combination of advantages in this class: smooth 6-cylinder inline diesel with turbocharging and twin-circuit cooling, electro-hydraulic power trim and a wide range of instruments fitted as standard. And a power-to-weight ratio that hails a new era in marine engineering: 121 kW (165 bhp) out of a stern drive unit that weighs only 470 kg (1061 lb).

Special features:

- One piece crankcase of cast iron built to the "tunnel" design, with transverse sections. Giving maximum stability and low weight
- 6 individual lightweight aluminium cylinder heads: better sealing properties with easy inexpensive maintenance
- Very quiet exhaust gas turbo-charger providing a smooth power curve throughout a wide engine speed range
- Aftercooler provides optimum efficiency
- Extra-large air filter for fresh air and a low noise level
- Water jacketed exhaust manifold made of V4A stainless steel
- Bosch distributor-type fuel injection pump with fuel supply geared to turbocharger pressure, maximum efficiency, improved fuel economy and considerably reduced exhaust emissions. Efficient com-

bustion to provide optimum running smoothness free of vibrations

- All fuel pipes made of steel for maximum safety
- Compact twin-circuit cooling system with integrated header tank, heat exchanger and thermostat, oil cooler and thermostat
- Maintenance-free direct drive salt water pump by the camshaft and single-belt drive of the circulation pump and alternator by the crankshaft
- Extra pulley for driving additional components
- Complete corrosion-proofing by the application of a special two-component paintwork in the advance and main painting process
- Stern drive fitted with power trim and tilt, trim gauge and warning buzzer to prevent excessive trimming

Conclusion:

The D190 Z has a wide range of exceptional advantages. This applies not only to the D190 Z but to all marine engines that bear the symbol of progressive engineering.

BMW's complete range of marine engines for motor yachts and sailing boats offers all kinds of options and a wide choice of diesel and petrol units. In addition, you can choose from a wide range of optional extras and accessories to meet your personal requirements. And to make sure that you enjoy sheer boating pleasure for a long time to come, BMW Marine's international dealer organization has trained marine technicians at your service as well as a reliable and quick supply of parts.